

TAPENER MAX

STRONG BIND HT-S45E(BL)

**INSTRUCTION MANUAL
MANUEL D'INSTRUCTIONS
INSTRUCCIONES DE USO
BEDIENUNGSANLEITUNG
MANUALE D'USO
사용 설명서**

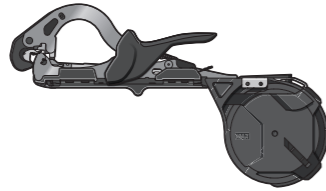

HT11752
191202-00/02

⚠ WARNING:

BEFORE USING THIS TOOL, STUDY THIS MANUAL TO ENSURE SAFETY WARNING AND INSTRUCTIONS. KEEP THESE INSTRUCTIONS WITH THE TOOL FOR FUTURE REFERENCE.

⚠ WARNUNG:

LESEN SIE VOR DER VERWENDUNG DIESES WERKZEUGS DIESE ANLEITUNG SORGFÄLTIG DURCH, UM DIE KENNNTNIS DER SICHERHEITSWARNUNGEN UND ANWEISUNGEN SICHERZUSTELLEN. BEWAHREN SIE DIESE ANWEISUNGEN ZUM SPÄTEREN NACHSCHLAGEN ZUSAMMEN MIT DEM WERKZEUG AUF.

⚠ AVERTISSEMENT :

AVANT D'UTILISER CET OUTIL, ÉTUDIEZ CE MANUEL AFIN DE PRENDRE CONNAISSANCE DES AVERTISSEMENTS ET DES INSTRUCTIONS. CONSERVEZ CES INSTRUCTIONS AVEC L'OUTIL POUR TOUTE CONSULTATION ULTÉRIEURE.

⚠ ATTENZIONE:

PRIMA DI UTILIZZARE QUESTO UTENSILE, STUDIARE IL PRESENTE MANUALE PER ASSICURARE LA COMPRESIONE DELLE AVVERTENZE DI SICUREZZA E DELLE ISTRUZIONI. CONSERVARE LE PRESENTI ISTRUZIONI INSIEME ALL'UTENSILE COME RIFERIMENTO FUTURO.

⚠ ADVERTENCIA:

ANTES DE USAR ESTA HERRAMIENTA, LEA DETENIDAMENTE ESTAS INSTRUCCIONES Y ASEGÚRESE DE RESPETAR LAS ADVERTENCIAS DE SEGURIDAD. CONSERVE ESTAS INSTRUCCIONES CON LA HERRAMIENTA PARA FUTURAS CONSULTAS.

⚠ 경고:

이 도구를 사용하기 전에, 이 설명서를 읽고 안전 경고와 지침을 확인하십시오. 나중에 참조할 수 있도록 이 설명서를 도구와 함께 보관하십시오.

SPECIFICATIONS / Caractéristiques / Spezifikationen / Presupuesto / Presupuesto / Specificazioni / 사양

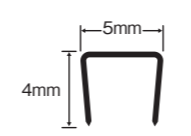
Name / Nom / Nombre / Bezeichnung / Nome / 이름	HT-S45E(BL)
Product code / Code produit / Código de producto / Produktcode / Codice prodotto / 제품 번호	HT90111
Dimensions / Dimensions / Dimensiones / Abmessungen / Dimensioni / 치수 / 外形尺寸	H170 × L400 × W40(mm)
Staples Used / Agrafes utilisées / Grapas utilizadas / Verwendete Heftklammern / Punti metallici utilizzati / 사용되는 스테이플	MAX STAPLES 404F-L
Number of Staples Loaded / Nombre d'agrafes chargées / Número de grapas cargadas / Anzahl eingelegter Heftklammern / Numero di punti metallici utilizzati / 들어가는 스테이플의 수	MAX STAPLES 404F-L (150pcs / stick)
Tape Used / Bande utilisée / Cinta utilizada / Verwendetes Band / Nastro utilizzato / 사용되는 테이프	MAX TAPE-T32B 0.25mm T × 9mm W × 32m L
Weight / Poids / Peso / Gewicht / Peso / 무게	540 grams
Bundling Limit / Limite de liage / Limite de atadura / Bündelhöchstgrenze / Limite di legatura / 바인딩 한도	Maximum 45mmφ
Blade / Lame / Cuchilla / Klinge / Lama / 날	BLADES FOR TAPNER Product code : TC90045
Staple's Full-Scale Figure / Illustration des agrafes à l'échelle 1 / Imagen de la grapa a escala completa / Abbildung einer Heftklammer im Originalmaßstab / Figura dei punti metallici in dimensioni reali / 스테이플의 실제 수치 (mm)	
Accessories / Accessoires / Accesorios / Zubehör / Accessori / 부속품	Hook : Parts No.55 Black screw(for attaching the hook) : Parts No.15

PARTS LIST / Liste des pièces / Lista de partes / Liste der Einzelteile / Elenco delle parti / 부품 목록

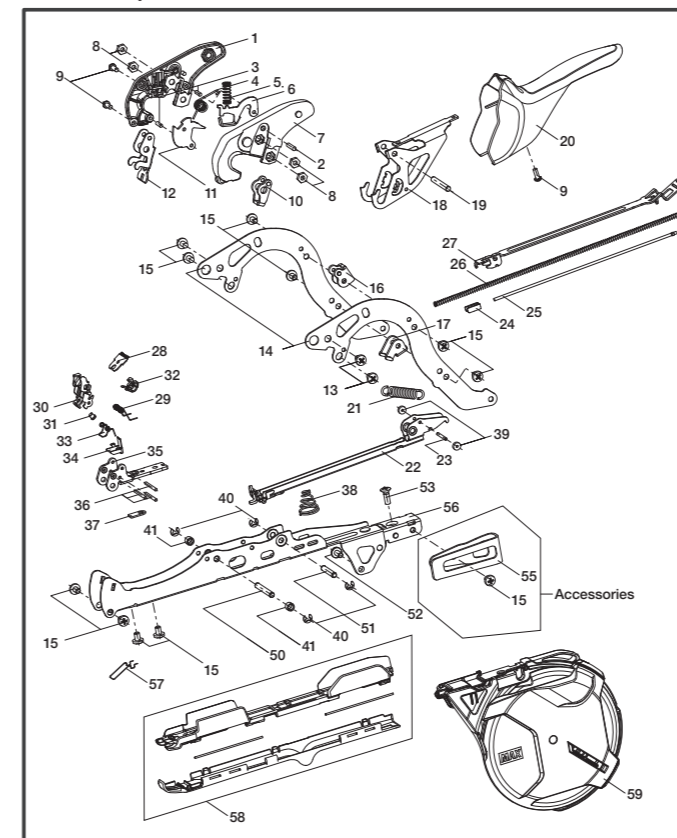

Index No.	Parts Code No.	Description
1	HT11672	B CASE S (HT-R)
2	FF31714	STRAIGHT PIN 1714
3	FF31712	STRAIGHT PIN 1712
4	KK33402	TORSION SPRING 3402
5	KK29130	COMPRESSION SPRING 9130

Index No.	Parts Code No.	Description
6	HT11670	LOCK PLATE S (HT-R)
7	HT11627	A CASE (HT-R)
8	CC43501	NUT M4(3)
9	AA05719	+PH TAP SCREW 3x8 (P)
10	HT11699	CLINCHER (HT-S)
11	HT11622	TAPE CATCH (HT-R)
12	HT11671	TAPE PLATE S (HT-R)
13	AA25537	SCREW BIND M4x6
14	HT11618	CLINCHER ARM(HT-R)
15	AA05716	SCREW BIND 4x6(S-TIGHT) (Accessories)
16	HT11619	ARM SUPPORT(HT-R)
17	HT11697	ARM SUPPORT S(HT-R)
18	HT11637	B HANDLE(HT-R)
19	FF31713	STRAIGHT PIN 1713
20	HT11704	GRIP(HT-S)
21	KK13405	EXTENSION SPRING 3405
22	HT70083	MAGAZINE UNIT (HT-S)
23	FF31716	STRAIGHT PIN 1716
24	HT11702	PUSHER(HT-S)
25	HT11610	SPRING GUIDE ROD(HT-R)
26	KK29131	COMPRESSION SPRING 9131
27	HT11701	STAPLE COVER(HT-S)
28	PRODUCT	BLADE
29	KK34099	TORSION SPRING 4099
30	HT70091	TAPE GUIDE UNIT (HT-S)
31	FF41740	STEP PIN 1740
32	HT11596	TAPE GUIDE SUPPORT(HT-R)
33	KK34101	TORSION SPRING 4101
34	HT11700	DRIVER (HT-S)
35	HT11707	TAPE GUIDE BASE (HT-S)
36	FF31711	STRAIGHT PIN 1711
37	HT11710	BACKUP WASHER(HT-S)
38	KK83018	CONICAL SPRING 3018
39	HT11669	RUBBER WASHER NBR90(HT-R)
40	JJ10404	E-RING 3.2
41	HT11615	ROLLER(HT-R)
50	FF31643	STRAIGHT PIN 1643
51	FF31644	STRAIGHT PIN 1644
52	AA05722	SCREW BIND 4x8(P)
53	AA23502	SCREW FLAT ROUND HEAD M4x12
55	HT11714	HOOK (HT-S) (Accessories)
56	HT70085	A HANDLE UNIT(HT-S)
57	HT11603	TAPE SPRING (HT-R)
58	HT70097	TAPE HOLDER ASSY(HT-S)
59	HT70095	BOBBIN CASE ASSY (HT-S)

HOW TO USE / MÉTHODE D'UTILISATION / MODO DE USO / VERWENDUNG / MODALITÀ D'USO / 사용 방법

Hook attachment / Crochet mont / Gancho montado / Haken montiert / Gancio montato / 훅 장착

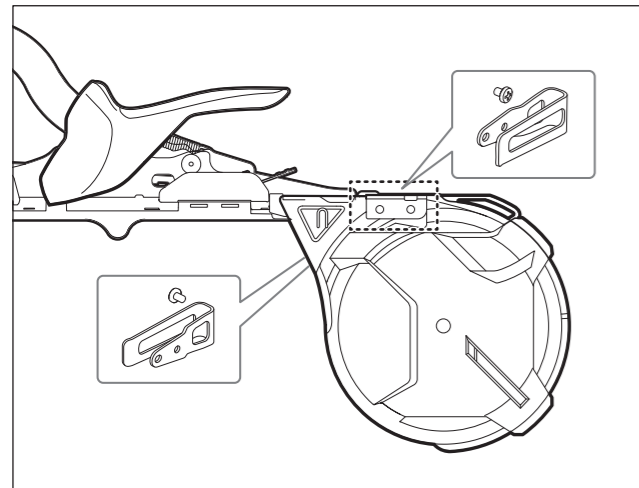

① How to Load Staples / Comment charger les agrafes / Cómo cargar las grapas / Einlegen der Heftklammern / Come caricare i punti metallici / 스테이플을 넣는 방법

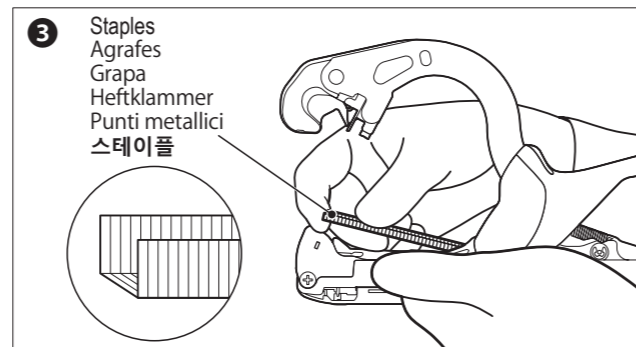
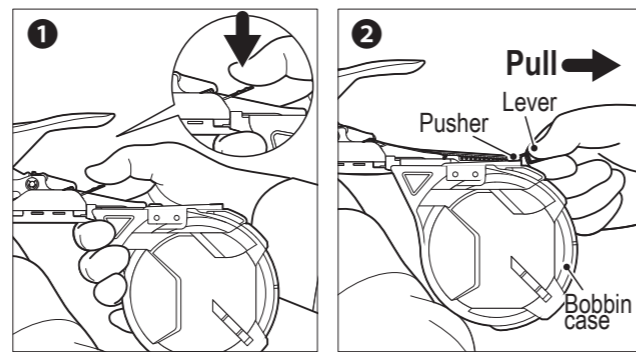

USE MAX STAPLE 404F-L / UTILISER MAX STAPLE 404F-L / UTILIZZA MAX STAPLE 404F-L / BENUTZEN SIE MAX 404F-L / USA MAX STAPLE 404F-L / 매크스의 스테이플을 사용하다 404F-L

② How to Load the Tape / Comment charger la bande / Cómo cargar la cinta / Einlegen des Bandes / Come caricare il nastro / 테이프 넣는 방법

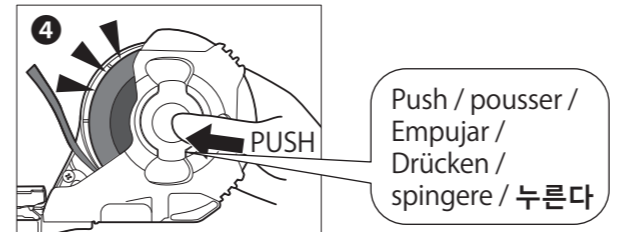
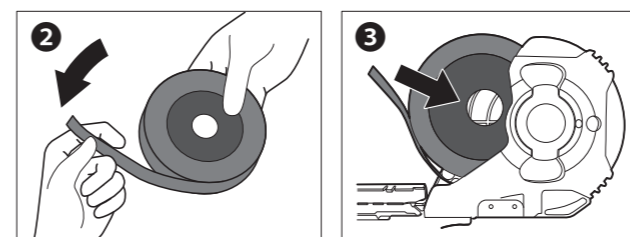
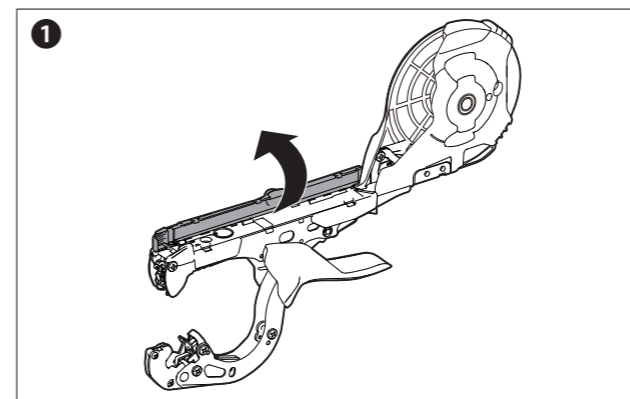

⚠ Caution

Do not remove the label / Ne pas enlever l'étiquette / No quite esta etiqueta / Dieses Etikett nicht entfernen / Non rimuovere questa etichetta / 이 라벨을 벗기지 말아 주세요

Do not remove the label.

PROHIBITION

⚠ Caution

Do not reload the same tape repeatedly / Ne pas recharger la même bande à plusieurs reprises. / No recargue la misma cinta repetidamente / Faden sie nicht das gleiche Band wiederholt / Non ricaricare ripetutamente lo stesso nastro / 같은 테이프를 되풀이해 재장전하지 마라

Do not reload.

PROHIBITION

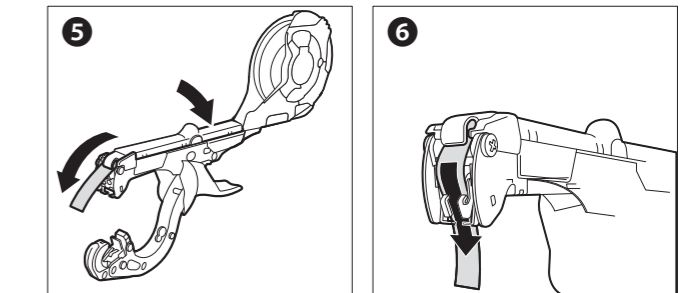

USE ONLY TAPE-T32B (TP91510)
USE MAX TAPE / UTILISER MAX RUBAN / UTILIZZA MAX CINTA / BENUTZEN SIE BAND / USA NASTRO MAX / 맥스 테이프를 쓸

③ How to remove the tape core / Comment faire pour supprimer le noyau de bande / Cómo eliminar el núcleo de la cinta / Wie man den Bandkern entfernt / Come rimuovere il nucleo del nastro / 테이프 중심의 떼는 방법

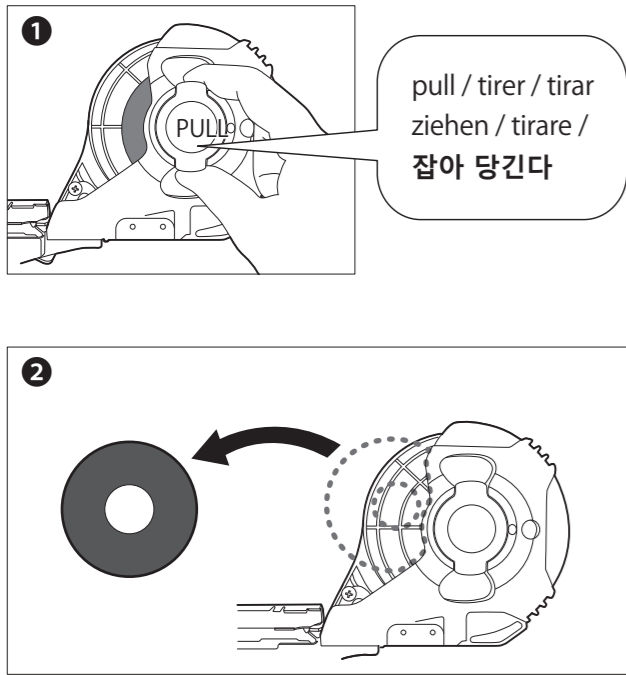

④ How to Bind Objects / Comment lier des objets / Cómo atar objetos / Zusammenbinden von Gegenständen / Come legare gli oggetti / 물건을 바인딩하는 방법

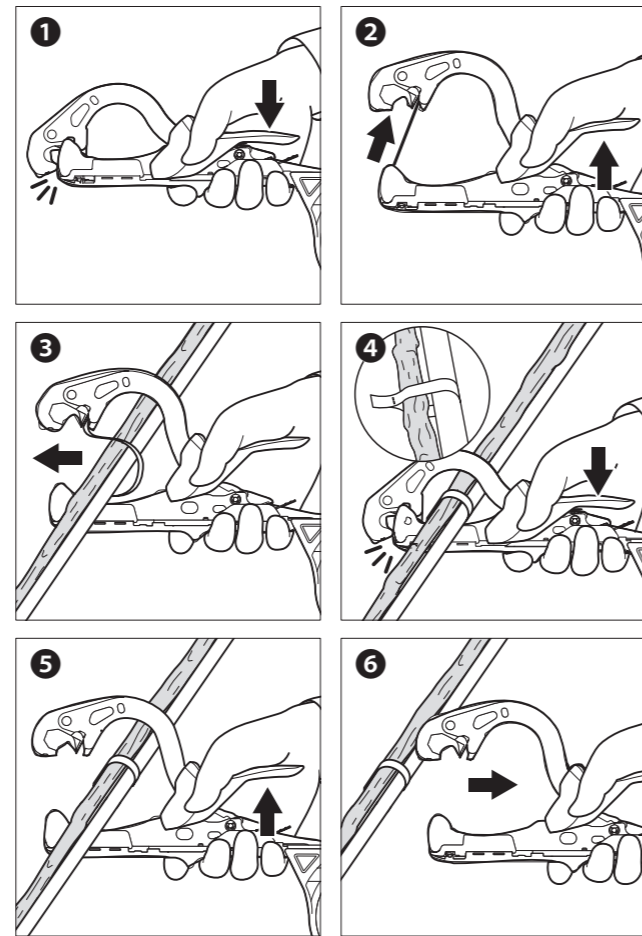

⑤ How to Change Blade / Comment changer de lame / Cómo cambiar la cuchilla / Auswechseln der Klinge / Come sostituire la lama / 날 교체 방법

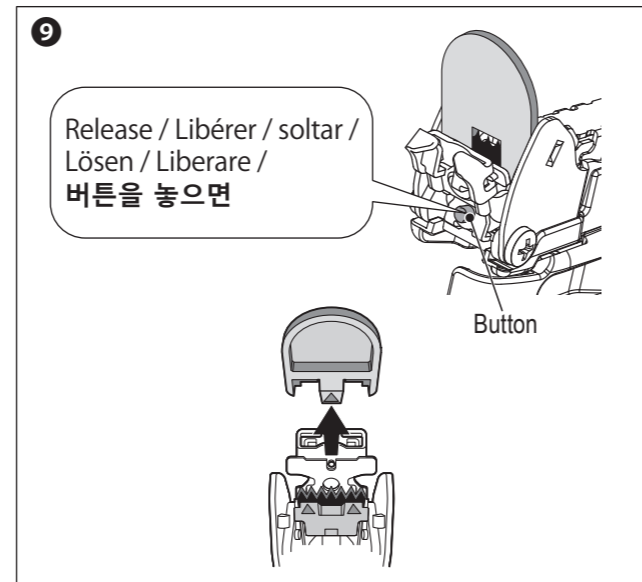
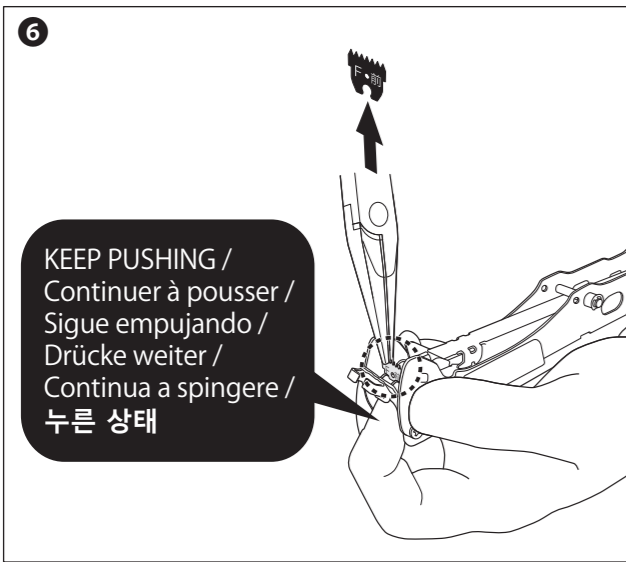
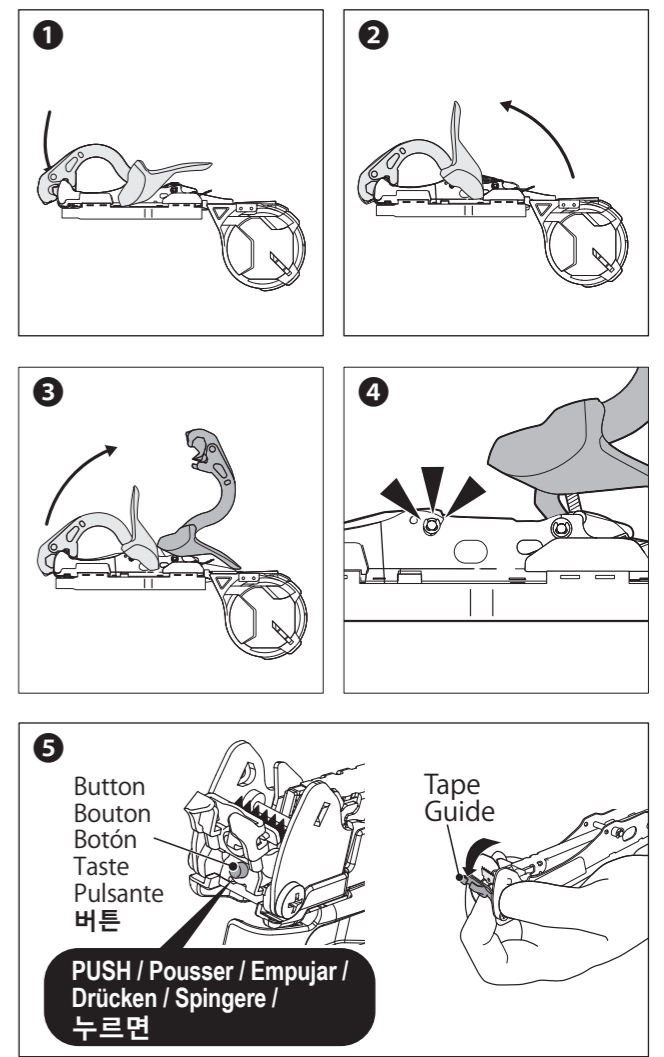
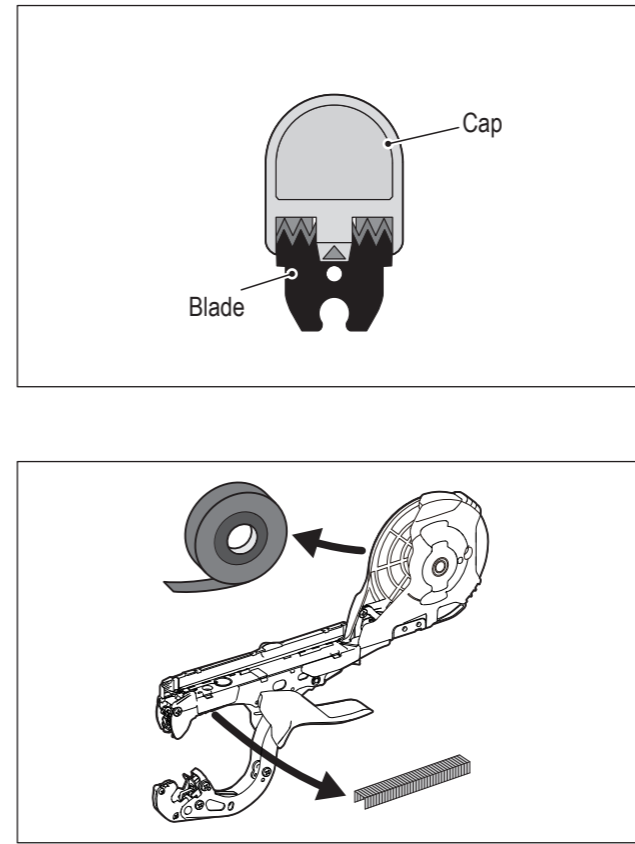

⑥ How to Remove Jammed Staples / Comment retirer des agrafes coincées / Cómo extraer grapas atascadas / Entfernen verklemmter Heftklammern / Come rimuovere i punti metallici inceppati / 걸린 스테이플을 제거하는 방법

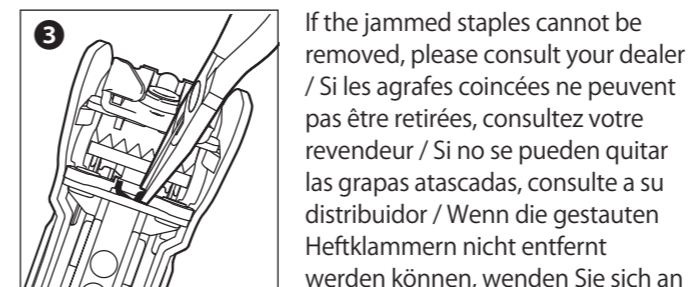
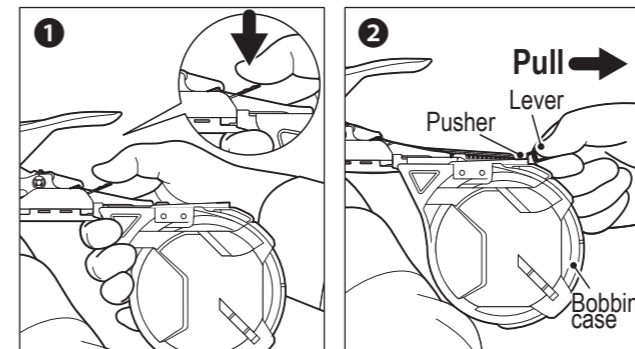

If the jammed staples cannot be removed, please consult your dealer / Si les agrafes coincées ne peuvent pas être retirées, consultez votre revendeur / Si no se pueden quitar las grapas atascadas, consulte a su distribuidor / Wenn die gestauten Heftklammern nicht entfernt werden können, wenden Sie sich an Ihren Händler / Se i punti inceppati non possono essere rimossi, consultare il rivenditore / 걸린 스테이플을 제거 할 수 없는 경우 대리점에 문의하십시오

⑦ AFTER USE / APRÈS UTILISATION / DESPUÉS DEL USO / NACH DER VERWENDUNG / DOPO L'USO / 사용 후
Apply oil / Appliquer de l'huile / Aplicar aceite / Öl auftragen / Applicare olio / 주유 위치

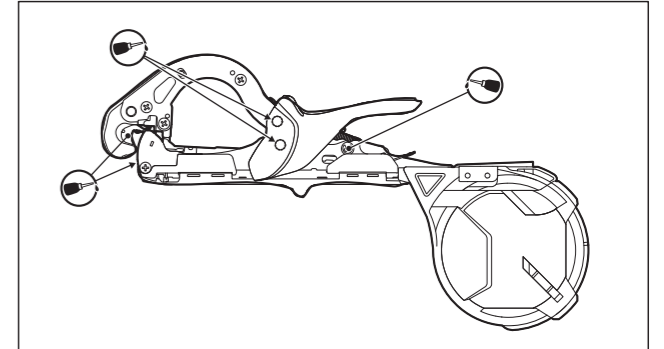

Turbin oils ISO VG32(JIS K 2213)

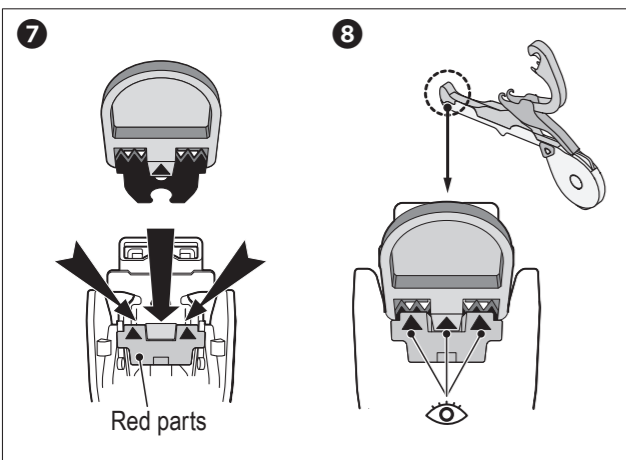

CHECK / Vérifier / Comprobar / Überprüfen / Verificare / 확인

